

HPE Aruba Networking 580 Series Outdoor Access Points

Installation Guide



Hewlett Packard
Enterprise

Copyright Information

© Copyright 2024 Hewlett Packard Enterprise Development LP.

Open Source Code

This product includes code licensed under certain open source licenses which require source compliance. The corresponding source for these components is available upon request. This offer is valid to anyone in receipt of this information and shall expire three years following the date of the final distribution of this product version by Hewlett Packard Enterprise Company. To obtain such source code, please check if the code is available in the HPE Software Center at <https://myenterpriselicense.hpe.com/cwp-ui/software> but, if not, send a written request for specific software version and product for which you want the open source code. Along with the request, please send a check or money order in the amount of US \$10.00 to:

Hewlett Packard Enterprise Company
Attn: General Counsel
WW Corporate Headquarters
1701 E Mossy Oaks Rd, Spring, TX 77389
United States of America



The HPE Aruba Networking 580 Series outdoor wireless access points (AP-584, AP-585 and AP-587) support the IEEE 802.11ax standard, delivering high performance with the MIMO (Multiple-Input, Multiple-Output) and OFDMA (Orthogonal Frequency Division Multiple Access) technologies, while also supporting 802.11a/b/g/n/ac wireless services.

Package Contents

- 580 Series access point
- M20 cable gland x 2
- USB Type-C console cable x 1
- Ground lug kit x 1
- 2.4GHz Vpol N-type BLE antenna x 1 (AP-584 only)

Tools Required

- Phillips screwdriver (#2 for M4x6 screw)
- Flat blade screwdriver (for Ethernet port cap)
- 8mm Allen or hex key (for USB console cap)



The weatherproof caps for Ethernet, AC and Console interfaces are connected to the access point, not loose in the package.



Mounting kits for use with the 580 Series access points are sold separately. Contact your HPE Aruba Networking sales representative for details.



Inform your supplier if there are any incorrect, missing, or damaged parts. If possible, retain the carton, including the original packing materials. Use these materials to repack and return the unit to the supplier if needed.

Hardware Overview

Figure 1 AP-584 Front View (with Aesthetic Cover)

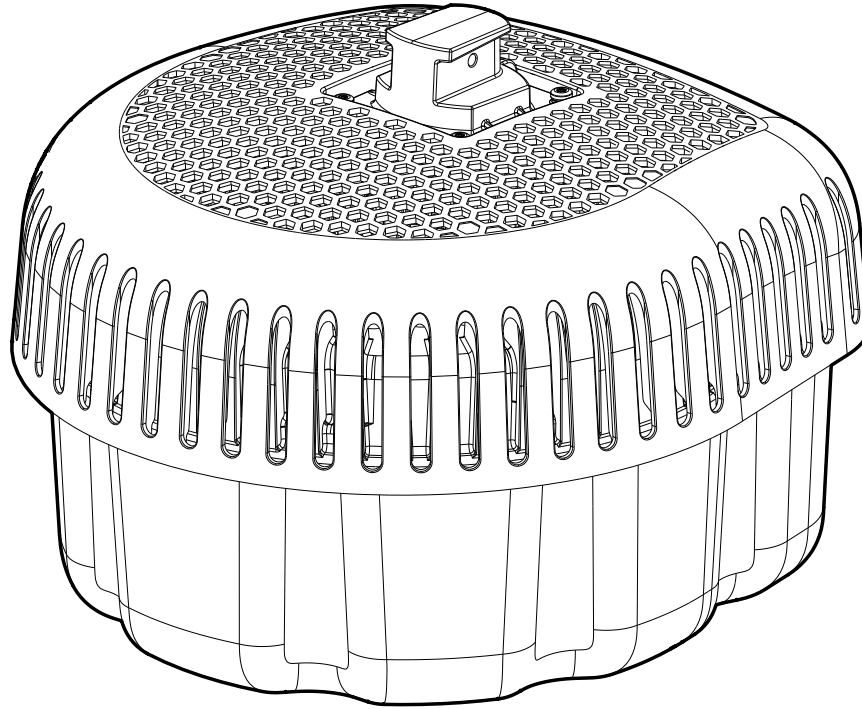

The antenna connectors of the AP-584 are covered by an aesthetic cover. The aesthetic cover can be removed when necessary. If leaving the cover in place, be careful not to exceed the antenna cable bend radius, or use proper angled connector cables to minimize cable bends.

Figure 2 AP-584 Rear View (with Aesthetic Cover)

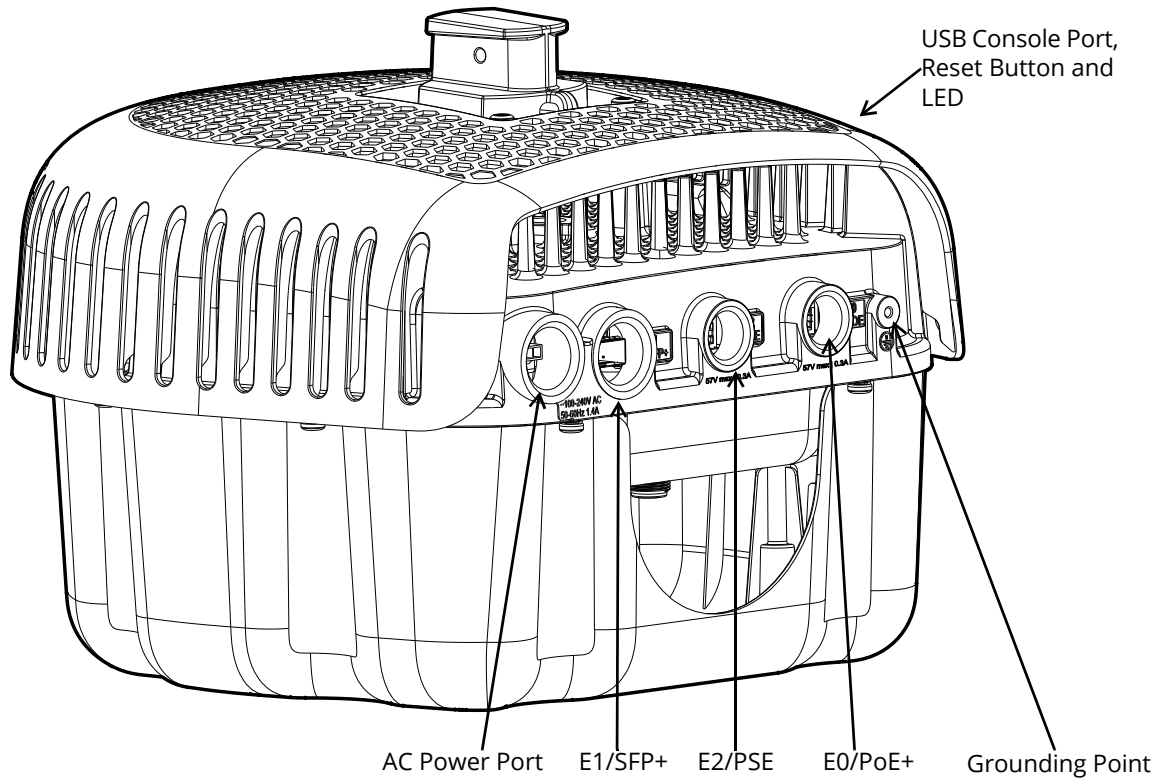

Figure 3 AP-585 Front View

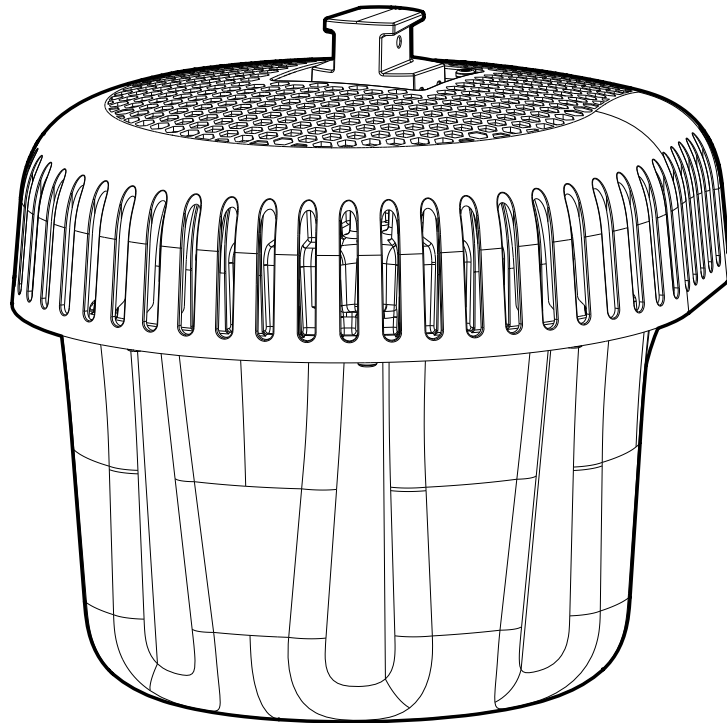

Figure 4 AP-585 Rear View

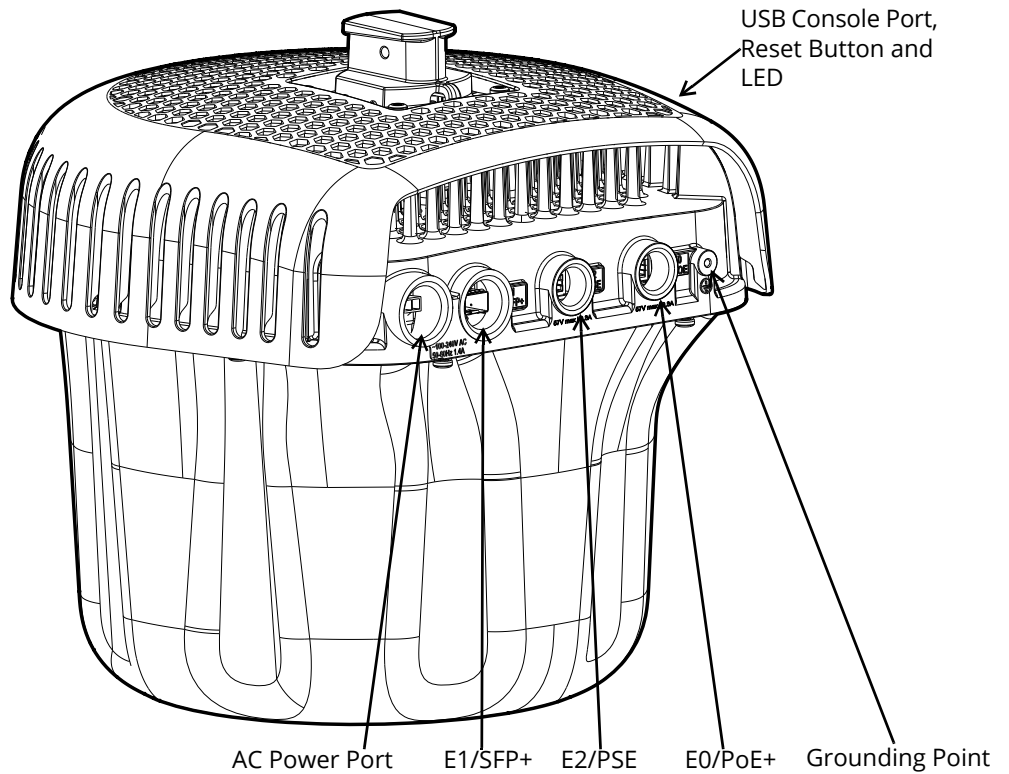

Figure 5 AP-587 Front View

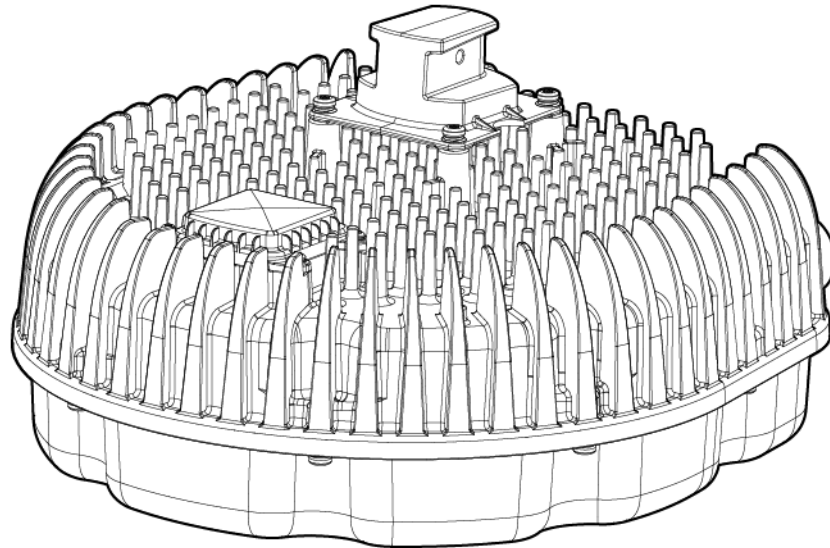
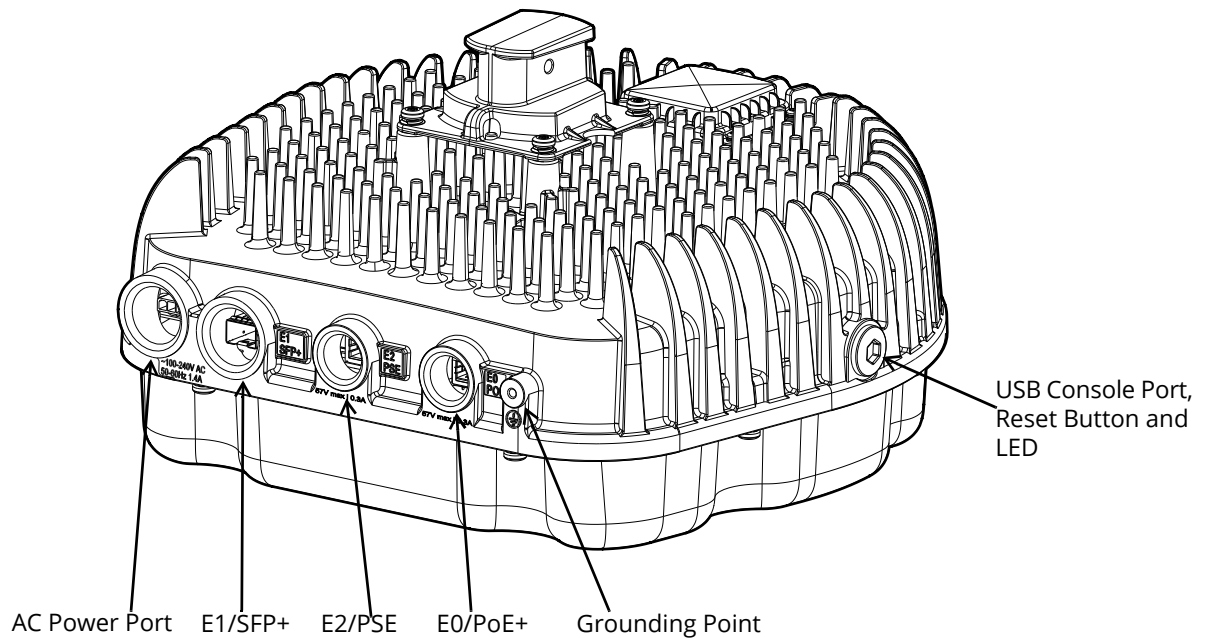

Figure 6 AP-587 Rear View



External Antenna Connectors

The AP-584 access point comes with four external Wi-Fi antenna connectors and one external BLE antenna connector. One 2.4GHz Vpol omni-directional N-type BLE antenna is included in the package of the AP-584 access point. A Wi-Fi antenna is not included in the package and must be purchased separately, refer to the 580 Series ordering guide on the HPE Aruba Networking website <https://www.arubanetworks.com>.



Mounting instructions for the antennas for the AP-584 access points are provided with the antennas. The mounting must be consistent with the instructions provided to ensure compliance with US and Canadian regulatory requirements when used outdoors.

External antennas for this device must be installed and serviced by a certified and trained technician, using manufacturer-approved antennas only.
The Equivalent Isotropically Radiated Power (EIRP) levels for all external antenna devices must not exceed the regulatory limit set by the host country/domain.
Installers are required to record the antenna gain for this device in the system management software.



Les antennes externes pour cet appareil doivent être installées par un professionnel de la mobilité certifié et formé, en utilisant uniquement des antennes approuvées par le fabricant.
Les niveaux équivalents de puissance à rayonnement isotrope (EIRP) pour tous les périphériques d'antenne externe ne doivent pas dépasser la limite réglementaire définie par le pays hôte / domaine.
Les installateurs doivent enregistrer le gain d'antenne pour cet appareil dans le logiciel de gestion du système.

Figure 7 AP-584 Bottom View (without Aesthetic Cover)

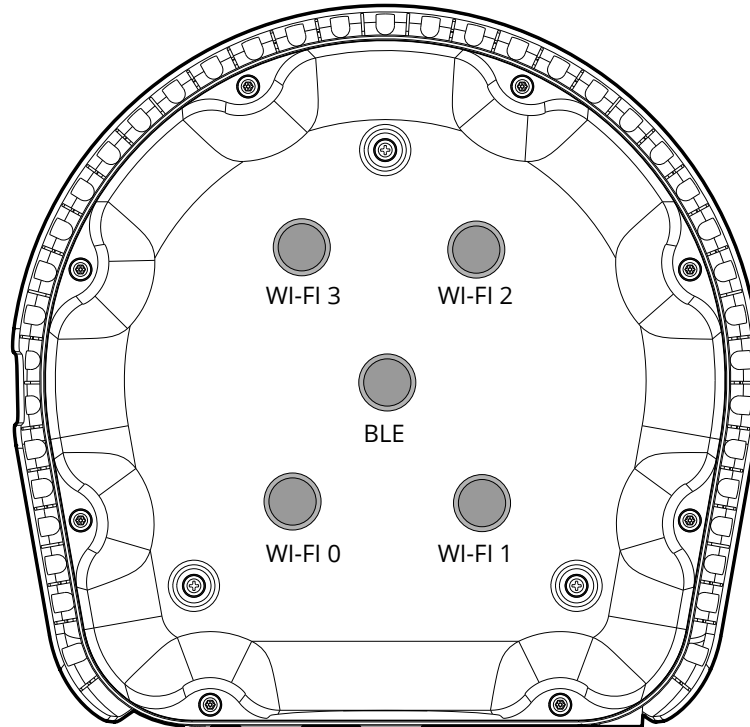

LED

The 580 Series access point is equipped with one LED that indicates the system status of the access point.

Table 1 580 Series LED Meanings during Boot Up

LED	Color/State	Meaning
System LED	Off	No power to AP
	Red	Initial power-up
	Flashing - Green	AP booting, not ready
	On - Green	AP ready. GbE (or better) or SFP+ connected. The LED turns off after 1200 seconds
	Green - Yellow, 6 seconds period	AP ready. 100Mbps connected. The LED turns off after 1200 seconds
	Green - Flashing ¹	AP in deep sleep
	Red - Flashing ²	AP in thermal shutdown

1. Mostly off (off 6 seconds, then one blink flash)

2. Equally off/on (off 1 second, then red 1 second)

Table 2 580 Series LED Meanings during Operation

LED	Color/State	Meaning
System LED	Solid Red	General fault - Immediate attention required
	One red blink every 3 seconds	Radio 0 fault (5 GHz)
	Two quick red blinks 0.5 seconds apart cycled every 3 seconds	Radio 1 fault (2.4GHz)

Ethernet Ports

The 580 Series access point is equipped with three Ethernet ports:

- E0 PoE+ port: 100/1000/2500/5000Base-T auto-sensing MDI/MDI-X wired network port (RJ45). The E0 port supports PoE-in, allowing the AP to draw power from an 802.3at/802.3bt PoE power source.
- E1 SFP+ port: 10GBASE-R SFP+ port.
- E2 PSE port: 100/1000Base-T auto-sensing MDI/MDI-X wired network port (RJ45). The AP supports 802.3af PoE-Out when PoE powered, and supports up to 802.3at when powered by AC.



NOTE

To enable 802.3at support on E2, Intelligent Power and Temperature Monitoring (IPTM) must be enabled on the AP to properly monitor and maintain safe operations of the AP under higher power draw requirements. If IPTM is disabled, the maximum PoE support on E2 is 802.3af.

PoE input rating is 57V max|0.3A. 0.3A is per pair of wires in Ethernet cable. Ethernet cable has 4 pair of wires in total.

AC Power Port

The 580 Series access point is equipped with an AC power port. The 580 Series access point does not ship with any AC power cables. HPE Aruba Networking offers an AC power connector kit (sold separately) for customers to assemble their own AC power cable.

Grounding Point

Always remember to protect the access point by installing the grounding line first before connecting to a network and applying power. Additionally, if removing or taking down the AP, the grounding line should be the last item disconnected.

USB Type-C Console Port

Use the included USB Type-C console cable to connect the access point to a laptop or a serial terminal for direct management.



Use an 8mm Allen or hex key to open the cover of the USB Console port.

Reset Button

The reset button can be used to reset the access point to factory default settings or turn off/on the LED display.

There are two ways to reset the access point to factory default settings:

Reset the AP during normal operation

Press and hold down the reset button using a small, narrow object such as a paper clip for more than 10 seconds during normal operation.

Reset the AP while powering up

1. Press and hold down the reset button using a small, narrow object such as a paper clip while the access point is not powered on via PoE.
2. Connect the power supply (PoE) to the access point while the reset button is being held down.
3. Release the reset button on the access point after 15 seconds.

To turn off/on the LED display, press and release the reset button using a small, narrow object, such as a paperclip for less than 10 seconds during normal operation of the access point.

Before You Begin

Refer to the sections below before beginning the installation process.



FCC Statement: Improper termination of access points installed in the United States configured to non-US model controllers will be in violation of the FCC grant of equipment authorization. Any such willful or intentional violation may result in a requirement by the FCC for immediate termination of operation and may be subject to forfeiture (47 CFR 1.80).

Pre-Installation Checklist

Before installing your access point, be sure that you have the following:

- Cat5E or better shielded cable with network access
- A compatible PoE injector with power cord

One of the following network services:

- Aruba Discovery Protocol (ADP)
- DNS server with an "A" record
- DHCP Server with vendor specific options



HPE Aruba Networking, in compliance with governmental requirements, has designed the 580 Series access points so that only authorized network administrators can change configuration settings. For more information about AP configuration, refer to the *AP Software Quick Start Guide*.



Access points are radio transmission devices and as such are subject to governmental regulation. Network administrators responsible for the configuration and operation of access points must comply with local broadcast regulations. Specifically, access points must use channel assignments appropriate to the location in which the access point will be used.

Outdoor Planning and Deployment Considerations

Prior to deploying an outdoor wireless network, the environment must be evaluated to plan for a successful WLAN deployment. Successfully evaluating the environment enables the proper selection of access points and antennas and assists in the determination of their placement for optimal RF coverage. This process is considered WLAN or RF planning and HPE Aruba Networking's system engineers can assist in the outdoor planning process.



The rules for the 5600-5650 MHz band vary by region.

Identifying Specific Installation Locations

Use the access point placement map generated by the HPE Aruba Networking RF Plan software application to determine the proper installation location(s). Each location should be as close as possible to the center of the intended coverage area and should be free from obstructions or obvious sources of interference. These RF absorbers/reflectors/interference sources will impact RF propagation and should be accounted for during the planning phase and adjusted for in the RF plan.



Use of this equipment in near proximity, either horizontally or vertically, with other equipment should be avoided because it could result in improper operation. If such use is necessary, this equipment and the other equipment should be observed to verify that they are operating normally.

Identifying Known RF Absorbers/Reflectors/Interference Sources

Identifying known RF absorbers, reflectors, and interference sources while in the field during the installation phase is critical. Make sure that these sources are taken into consideration when you attach an access point to its fixed location.

RF absorbers include:

- Cement/concrete—Old concrete has high levels of water dissipation, which dries out the concrete, allowing for potential RF propagation. New concrete has high levels of water concentration in the concrete, blocking RF signals.
- Natural Items—Fish tanks, water fountains, ponds, and trees
- Brick

RF reflectors include:

- Metal Objects—Metal pans between floors, rebar, fire doors, air conditioning/heating ducts, mesh windows, blinds, chain link fences (depending on aperture size), refrigerators, racks, shelves, and filing cabinets.
- Do not place an access point between two air conditioning/heating ducts. Make sure that access points are placed below ducts to avoid RF disturbances.

RF interference sources include:

- Other Wi-Fi networks
- Microwave ovens
- Bluetooth devices

Access Point Installation



Service to all HPE Aruba Networking products should be performed by trained service personnel only.



Metal cover of enclosure is intended for installation in restricted access location.

Using Mount Kits

The 580 Series access point can be installed on a wall or attached to a pole by using mount kits:

Part Number	Description	Supported Model
R9H97A	AP-OUT-MNT-V1A Aruba Outdoor AP Pole/Wall Long Mount Kit.	AP-584/AP-585: Wall or Pole
JW054A	AP-270-MNT-H1 Aruba Outdoor AP Hanging or Tilt Install Mount Kit.	AP-587: Wall or Pole AP-584/AP-585: Flat or Sloped Ceiling
JW055A	AP-270-MNT-H2 Aruba Outdoor AP Access Flush Wall or Ceiling Mount.	AP-587: Wall AP-584/AP-585: Flat Ceiling
R6W11A	AP-270-MNT-H3 Aruba Outdoor AP Hanging or Dual-Tilt Install Mount Kit.	AP-587: Wall or Pole AP-584/AP-585: Flat or Sloped Ceiling



The 580 Series access point does not ship with any mount kits. These mount kits are available as accessories and must be ordered separately.



For installation instructions on mount kits, please refer to their respective installation guides found on the HPE Networking support site <https://networkingsupport.hpe.com/home>.



This 580 Series access point is intended for installation in a RESTRICTED ACCESS LOCATION attached to a pole or installed on a wall. Installers should disconnect power before working with or near the access point.



To prevent dropping and damage to the 580 Series access point, extra care should be taken when handling the access point.

Grounding the Access Point

Grounding the access point must be completed before powering up the device. The ground wire should be #8 AWG.

1. Strip the insulating jacket off of one end of the ground wire and place the bare conductor into the ground lug (included in the package), then crimp the connection by pressing firmly with the crimping pliers.
2. Fasten the ground lug to the grounding point on the access point with the screw included in the package.

Connecting the Ethernet Cable

To connect the Ethernet cable to the access point, perform the following steps using the M20 cable glands that ship with your access point.



Failure to use the included cable glands can lead to connectivity and PoE issues.



The cable is not included and must be purchased separately. Purchase a suitable UV-resistant, outdoor rated, CAT 5E or better shielded cable for use with the access point.

Figure 8 Ethernet Cable and M20 Cable Gland Assembly

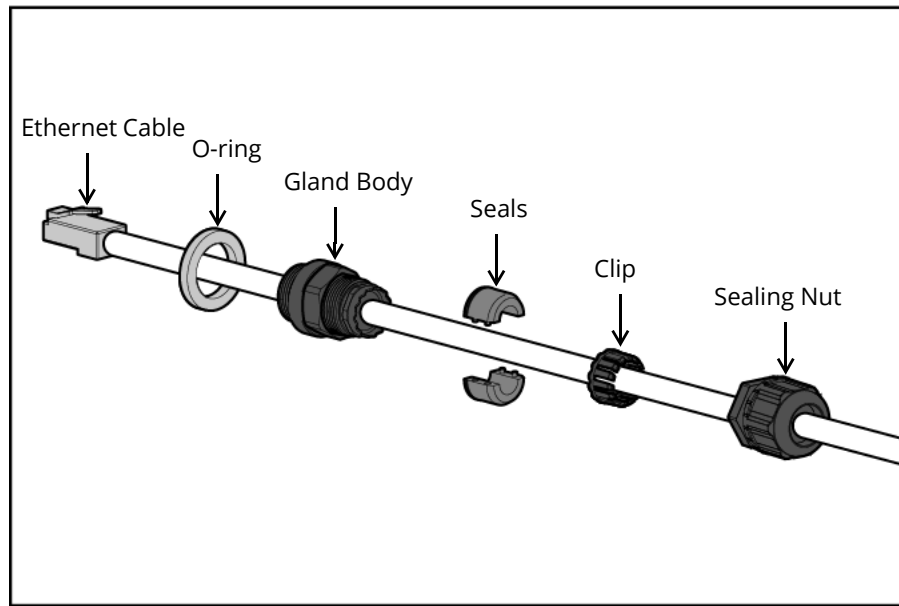

1. Remove the dust cap from the Ethernet port
2. Slide the sealing nut, clip, gland body and O-ring over the cable.
3. Insert the RJ45 connector to the Ethernet port.
4. Place the O-ring on the gland body, and ensure it is in place.
5. Thread the gland body into the Ethernet port and tighten to a torque of 8.9 in/lbs (1.0 Nm).
6. Combine the two split seals over the cable, and push towards the gland body until located at the recess of the gland body.
7. Move the clip towards the gland body, passing over the seals, until the wavy end of the clip properly fits into the wavy end of the gland body.
8. Tighten the sealing nut onto the gland body to a torque of 8.9 in/lbs (1.0 Nm).



Two sets of seals are provided in the package for use with the Ethernet cables. One is applicable for cables with 4-6 mm diameter, and the other is applicable for cables with 6-10 mm diameter.

Figure 9 Ethernet Cable and M20 Cable Gland Installed to AP

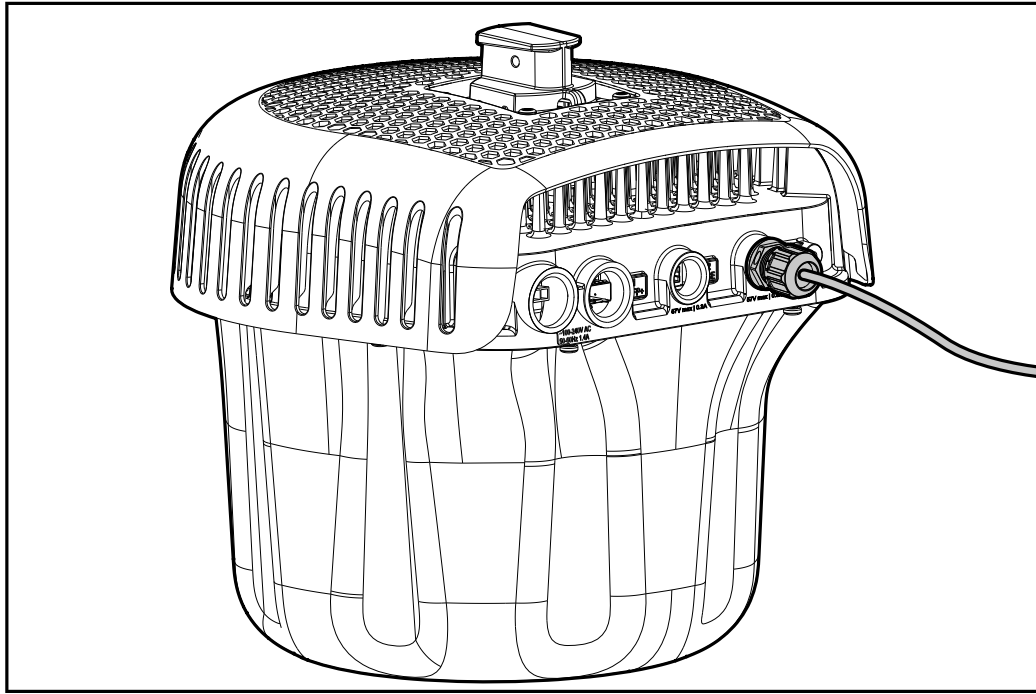

Connecting the Fiber-optic Cable



The fiber-optic cable is not included in the package and must be purchased separately. Purchase a suitable 6-12 mm diameter, UV-resistant, outdoor rated cable for use with the access point.

The CKIT-OD-SFP SFP cable gland is not included in the package and must be purchased separately, refer to the 580 Series ordering guide on the HPE Aruba Networking website <https://www.arubanetworks.com>.

Figure 10 Fiber-optic Cable and CKIT-OD-SFP SFP Cable Gland

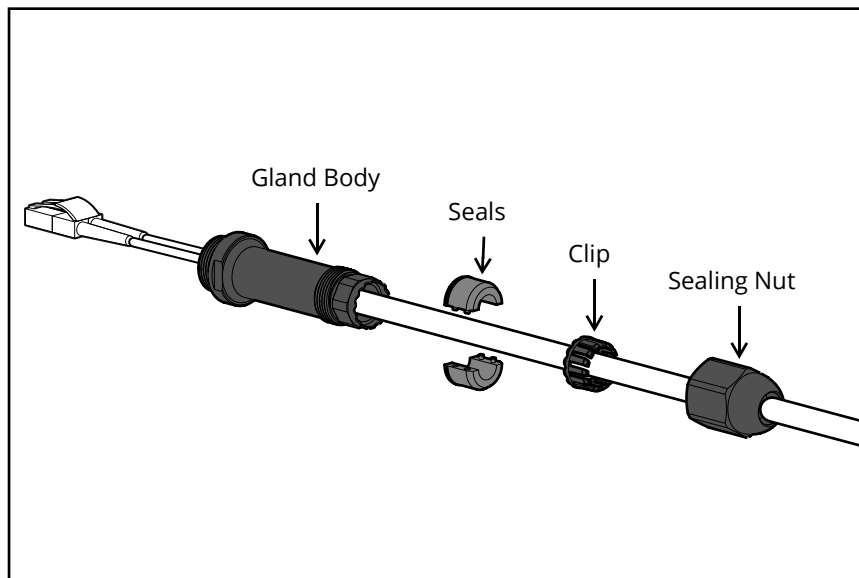

To connect the fiber-optic cable to the access point, perform the following steps.

1. Remove the dust cap from the E1 SFP+ port.
2. Insert the transceiver module into the SFP+ port, and ensure it is in place.

3. Slide the sealing nut, clip, seals and gland body over the fiber-optic cable.
4. Insert the connector of the fiber-optic cable into the transceiver module, and ensure the connector is firmly in place.
5. Thread the gland body into the E1 SFP+ port on the AP and tighten to a torque of 45 in/lbs (5.0 Nm).
6. Combine the two split seals over the cable, and push towards the gland body until located at the recess of the gland body.
7. Move the clip towards the gland body, passing over the seals, until the wavy end of the clip properly fits into the wavy end of the gland body.
8. Tighten the sealing nut onto the gland body to a torque of 36 in/lbs (4.0 Nm).

Figure 11 Fiber-optic Cable and CKIT-OD-SFP SFP Cable Gland Installed to AP

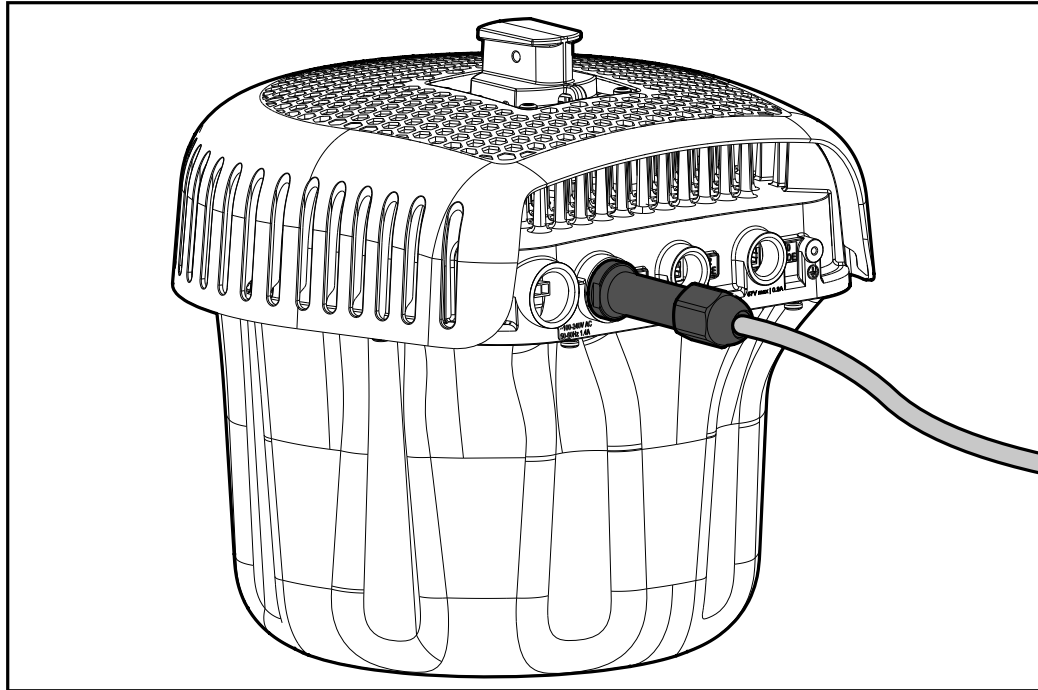

Connecting the AC Power Cable

Best Practice for Outdoor Connection to AC Mains

In all circumstances and with any outdoor infrastructure the recommended practice is to connect to AC mains in an outdoor grade weather protected junction box. This needs to be implemented by a qualified resource in a manner that is consistent with the electrical code in force in the jurisdiction of deployment. In many countries this will require a licensed electrician to perform this operation. In Japan, this would be performed by a Certified Electrician by Ministry of Economy, Trade and Industry.

The use of plugs with infrastructure equipment is suitable only for temporary installs where nuisance tripping of GFI plugs is considered tolerable. If a plug is desired for attachment to the cable assemblies then the installer is expected to follow all directions provided with the plug end in a fashion consistent with local electrical code.

接続ケーブル、電源コード、ACアダプタ、バッテリーなどの部品は、必ず添付品または指定品をご使用ください。また、電源ケーブルは弊社が指定する製品以外の電気機器には使用できないためご注意ください。



Translation: Please only use included or HPE Aruba Networking specified cables, power cords, AC power supplies and batteries. The power cord should not be used with other electric equipment than what is specified by HPE Aruba Networking.



The AC port's PE and AP ground is connected together in the AP. Users can decide if the AC port's PE shall be connected to the power outlet according to the requirement of the local AP power system or the local electrician's guidance.

Assembling the AC Power Cable

The 580 Series access point does not ship with any AC power cables. HPE Aruba Networking offers an AP-AC-MLX outdoor Molex AC connector kit (sold separately) for customers to assemble their own AC power cable. For installation instructions on the AP-AC-MLX kit, refer to the AP-AC-MLX AC Connector Kit Installation Guide shipped with the AP-AC-MLX kit.

The required specifications for third party cable used with the AP-AC-MLX outdoor Molex AC connector kit are as follows:

- AC power cable specifications: UV-resistant, outdoor-rated three-wire AC cable (18 AWG) with outside cable diameter of 6-12mm and inside wire diameter no more than 3.1mm

Connecting the AC Power Cable

To connect the AC power cable to the access point, assemble the AC power cable as instructed in the installation guide of the AP-AC-MLX outdoor AC connector kit (sold separately), and then perform the following steps using the M25 cable gland (included in the AP-AC-MLX kit).

1. Remove the weatherproof cap on the AC power port.
2. Slide the sealing nut, clip, gland body and O-ring over the cable. See [Figure 12](#).

Figure 12 AC Power Cable and M25 Cable Gland

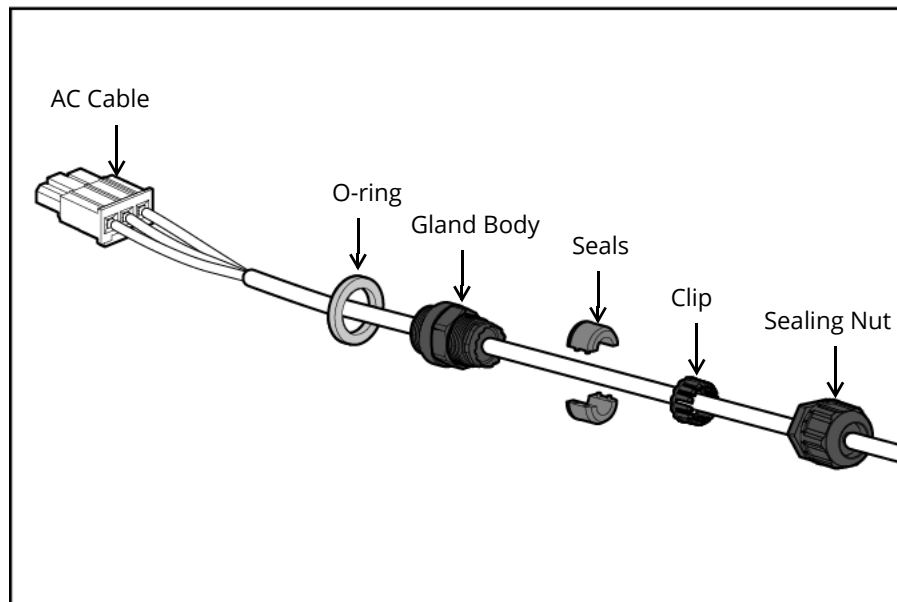

3. Insert the power cable connector into the AC power port.

Figure 13 Inserting AC Cable Connector into AC Power Port on AP

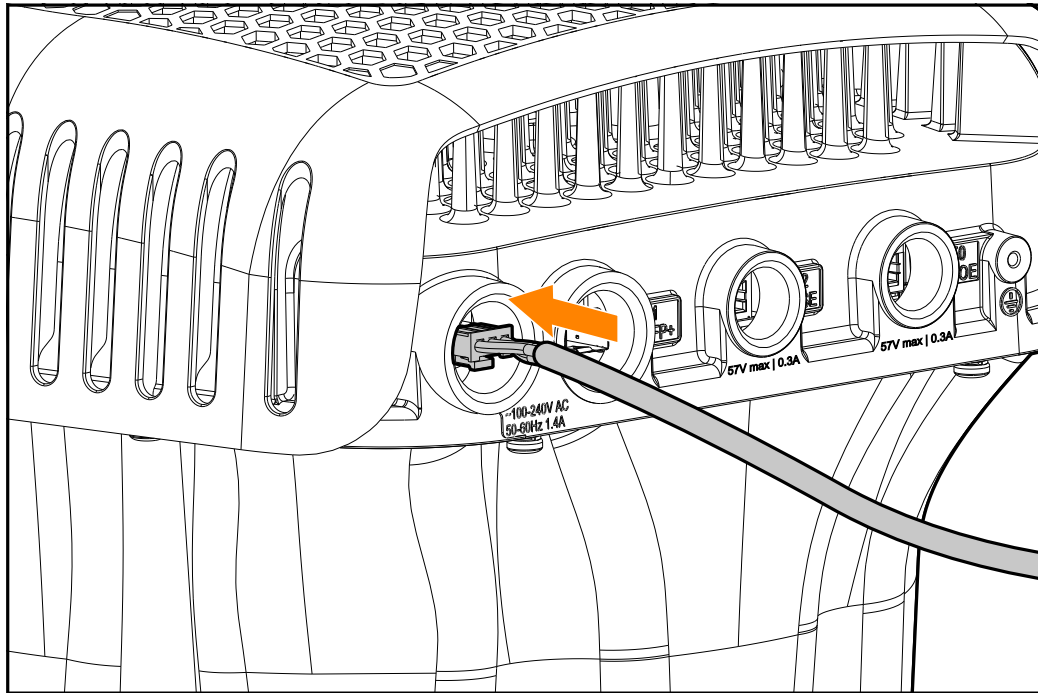

4. Place the O-ring on the gland body, and ensure it is in place.
5. Thread the gland body into the AC power port and tighten to a torque of 10.6 in/lbs (1.2 Nm).
6. Combine the two split seals over the cable, and push towards the gland body until located at the recess of the gland body.
7. Move the clip towards the gland body, passing over the seals, until the wavy end of the clip properly fits into the wavy end of the gland body.
8. Tighten the sealing nut onto the gland body to a torque of 10.6 in/lbs (1.2 Nm).

Figure 14 AC Power Cable and M25 Cable Gland installed to AP

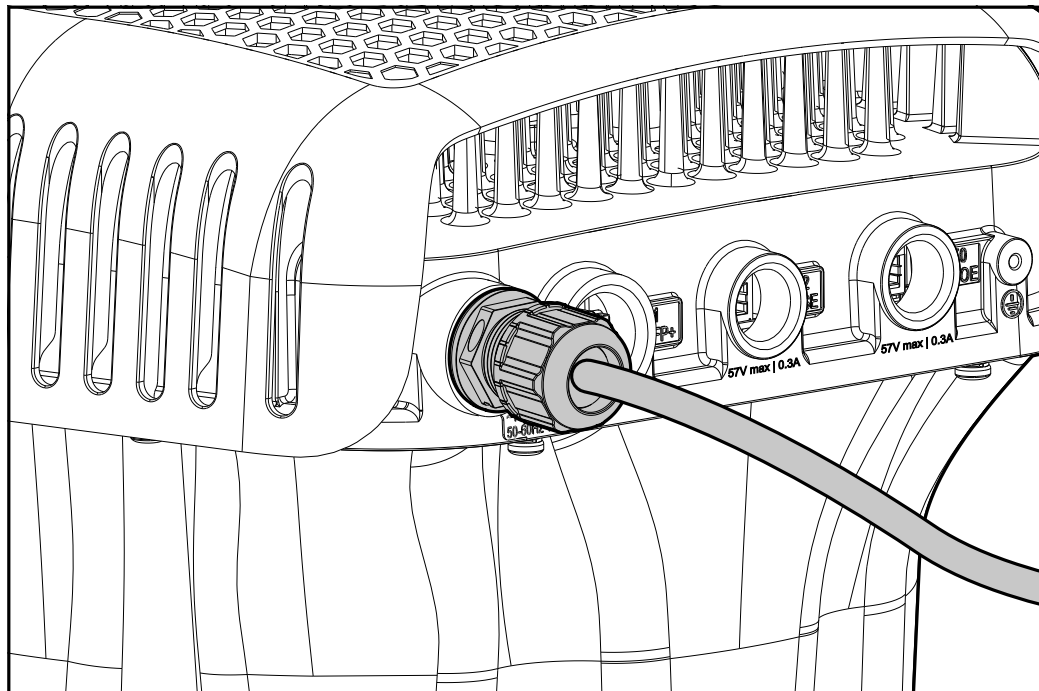

Software

For instructions on choosing operating modes and initial software configuration, refer to the AP Software Quick Start Guide.



HPE Aruba Networking access points are classified as radio transmission devices, and are subject to government regulations of the host country. The network administrator(s) is/are responsible for ensuring that configuration and operation of this equipment is in compliance with their country's regulations. For a complete list of approved channels in your country, refer to the *HPE Aruba Networking Downloadable Regulatory Table* at <https://www.arubanetworks.com/techdocs/DRT/Default.htm>

Verifying Post-Installation Connectivity

The integrated LEDs on the access point can be used to verify that the access point is receiving power and initializing successfully (see [Table 1](#) and [Table 2](#)). Refer to the **AP Software Quick Start Guide** for further details on verifying post-installation network connectivity.

Electrical and Environmental Specifications

Electrical

- Ethernet
 - E0 PoE+ port: 100/1000/2500/5000Base-T auto-sensing MDI/MDI-X wired network port (RJ45). The E0 port supports PoE-in, allowing the AP to draw power from an 802.3at/802.3bt PoE power source.
 - E1 SFP+ port: 10GBASE-R SFP+ port.
 - E2 PSE port: 100/1000Base-T auto-sensing MDI/MDI-X wired network port (RJ45). The AP supports 802.3af PoE-Out when PoE powered, and supports up to 802.3at when powered by AC.

Environmental

- Operating
 - Temperature: -40°C to 65°C (-40°F to 149°F)



If the 580 Series access point is deployed supporting Fiber, PSE, and high user loads in extremely hot temperatures or in hot environments with large solar loading environments, it is strongly recommended to enable Intelligent Power and Temperature Monitoring (IPTM) to ensure continuous uninterrupted operations, allowing the AP to disable specific and user-definable features to ensure continuity and prevent a thermal shutdown of the AP.

- Storage
 - Temperature: -40°C to 70°C (-40°F to 158°F)
 - Humidity: 5% to 93% non-condensing

For additional specifications on this product, please refer to the data sheet at www.arubanetworks.com.

BLE Radio Default State

When the Access Point is in factory default state the integrated BLE radio is enabled. This applies to the non-TAA/FIPS product SKUs only. On the TAA/FIPS products, the BLE radio is disabled when the unit is in factory default conditions. Once the AP has established a connection with its management platform, the BLE radio state is updated to match what's configured there. This state is maintained if the AP is power-cycled or rebooted.

Console Port Default State

When the Access Point is in factory default state the console interface (both physical port and BLE) is enabled with default credentials (username is "admin" and password is the serial number of the unit). Once the AP has established a connection with its management platform, the console port state (enabled/disabled) and access credentials are updated to match what's configured there. State and credentials are maintained if the AP is

power-cycled or rebooted.

Regulatory Model Number

For the purpose of regulatory compliance certifications and identification, this product has been assigned a unique regulatory model number (RMN). The regulatory model number can be found on the product nameplate label, along with all required approval markings and information. When requesting compliance information for this product, always refer to this regulatory model number. The regulatory model number RMN is not the marketing name or model number of the product.

The following regulatory model numbers apply to the 580 Series:

- AP-584 RMN: APEX0584
- AP-585 RMN: APEX0585
- AP-587 RMN: APEX0587

Safety and Regulatory Compliance



RF Radiation Exposure Statement: This equipment complies with RF radiation exposure limits. This equipment should be installed and operated with a minimum distance of 9.84 inches (25cm) between the radiator and your body for 2.4 GHz and 5 GHz operations. This transmitter must not be co-located or operating in conjunction with any other antenna or transmitter.



Déclaration de la concernant l'exposition aux rayonnements à fréquence radioélectrique (FR): Cet appareil est conforme aux limites d'exposition aux rayonnements FR établies par la FCC. Il doit être installé et utilisé à une distance minimale de 25 cm (9,84 pouces) entre le radiateur et votre corps, qu'il opère sur la bande 2,4 GHz ou 5 GHz. Cet émetteur ne doit pas être installé ou utilisé à proximité immédiate d'une autre antenne ni d'un autre transmetteur.



The device could automatically discontinue transmission in case of absence of information to transmit, or operational failure. Note that this is not intended to prohibit transmission of control or signaling information or the use of repetitive codes where required by the technology.



Changes or modifications to this unit not expressly approved by the party responsible for compliance could void the user's authority to operate this equipment.



Toute modification effectuée sur cet équipement sans l'autorisation expresse de la partie responsable de la conformité est susceptible d'annuler son droit d'utilisation.

United States

This equipment has been tested and found to comply with the limits for a Class B digital device, pursuant to Part 15 of the FCC Rules. These limits are designed to provide reasonable protection against harmful interference in a residential installation. This equipment generates, uses and can radiate radio frequency energy and, if not installed and used in accordance with the manufacturer's instructions, may cause harmful interference to radio communications. However, there is no guarantee that interference will not occur in a particular installation. If this equipment does cause harmful interference to radio or television reception, which can be determined by turning the equipment off and on, the user is encouraged to try to correct the interference by one or more of the following measures:

- Reorient or relocate the receiving antenna.
- Increase the separation between the equipment and receiver.
- Connect the equipment to an outlet on a circuit different from that to which the receiver is connected.
- Consult the dealer or an experienced radio or TV technician for help.

Improper termination of access points installed in the United States configured to a non-US model controller is a violation of the FCC grant of equipment authorization. Any such willful or intentional violation may result in a requirement by the FCC for immediate termination of operation and may be subject to forfeiture (47 CFR 1.80).

Innovation, Science and Economic Development Canada

This Class B digital apparatus meets all of the requirements of the Canadian Interference-Causing Equipment Regulations.

In accordance with Innovation, Science and Economic Development Canada regulations, this radio transmitter and receiver may only be used with an antenna, the maximum type and gain of which must be approved by Innovation, Science and Economic Development Canada. To reduce potential radio interference, the type of antenna and its gain shall be chosen so that the equivalent isotropic radiated power (EIRP) does not exceed the values necessary for effective communication.

This device complies with Innovation, Science and Economic Development Canada's license-exempt RSS regulations. Operation of this device is subject to the following two conditions: (1) this device may not cause interference, and (2) this device must accept any interference, including interference that may cause undesired operation.

When operated in 5.15 to 5.25 GHz frequency range, this device is restricted to indoor use to reduce the potential for harmful interference with co-channel Mobile Satellite Systems.

This radio transmitter model APEX0584 has been approved by Innovation, Science and Economic Development Canada to operate with the antenna types listed in the online ordering guide (link provided below) with the maximum permissible gain indicated. Antenna types not included in this list, having a greater gain than the maximum gain indicated for that type, are strictly prohibited for use with this device.

https://www.arubanetworks.com/assets/og/OG_AP-580Series.pdf

Innovation, Sciences et Développement économique Canada

Cet appareil numérique de Classe B répond à toutes les exigences de la réglementation canadienne sur le matériel brouilleur.

Conformément à la réglementation d'Innovation, Sciences et Développement économique Canada, le présent émetteur-récepteur radio ne peut être utilisé qu'avec une antenne d'un type et d'un gain maximal approuvé par Innovation, Sciences et Développement économique Canada. Dans le but de réduire les risques d'interférence radioélectrique, il faut choisir le type d'antenne et son gain de sorte que la puissance isotrope rayonnée équivalente (P.I.R.E.) ne dépasse pas les valeurs nécessaires à l'établissement d'une communication efficace.

Ce périphérique est conforme à la réglementation CNR d'Innovation, Sciences et Développement économique Canada applicable aux appareils radio exempts de licence. L'utilisation de ce périphérique est soumise aux deux conditions suivantes : (1) ce périphérique ne doit pas provoquer d'interférences, et (2) ce périphérique doit accepter toute interférence, y compris les interférences susceptibles de provoquer un dysfonctionnement. Pour un fonctionnement dans la bande de fréquences comprises entre 5,15 et 5,25 GHz, son utilisation est limitée à un environnement intérieur afin de réduire la possibilité d'interférences nuisibles avec les systèmes mobiles par satellite opérant sur le même canal.

Ce modèle d'émetteur radio APEX0584 a été approuvé par Innovation, Sciences et Développement économique Canada pour fonctionner avec les types d'antenne énumérés dans le guide de commande en ligne (lien ci-dessous) avec le gain maximal admissible indiqué. Les types d'antennes non inclus dans cette liste, ayant un gain supérieur au gain maximal indiqué pour ce type, sont strictement interdits pour une utilisation avec cet appareil.

https://www.arubanetworks.com/assets/og/OG_AP-580Series.pdf

European Union Regulatory Conformance

The Declaration of Conformity made under Radio Equipment Directive 2014/53/EU is available for viewing at: www.hpe.com/eu/certificates. Select the document that corresponds to your device's model number as it is indicated on the product label.

This radio transmitter model has been approved to operate with the antenna types listed in the online ordering guide (link provided below) with the maximum permissible gain indicated. Antenna types not included in this list, having a greater gain than the maximum gain indicated for the type, are strictly prohibited for use with this device. Compliance is only assured if the HPE Aruba Networking approved accessories as listed in the ordering guide are used.

https://www.arubanetworks.com/assets/og/OG_AP-580Series.pdf

Wireless Channel Restrictions

5150-5350MHz band is limited to indoor only in the following countries; Austria (AT), Belgium (BE), Bulgaria (BG),

Croatia (HR), Cyprus (CY), Czech Republic (CZ), Denmark (DK), Estonia (EE), Finland (FI), France (FR), Germany (DE), Greece (GR), Hungary (HU), Iceland (IS), Ireland (IE), Italy (IT), Latvia (LV), Liechtenstein (LI), Lithuania (LT), Luxembourg (LU), Malta (MT), Netherlands (NL), Norway (NO), Poland (PL), Portugal (PT), Romania (RO), Slovakia (SK), Slovenia (SL), Spain (ES), Sweden (SE), Switzerland (CH), Turkey (TR), United Kingdom (UK(NI)).

Radio	Frequency Range MHz	Max EIRP
BLE/Zigbee	2402-2480	10 dBm
Wi-Fi	2412-2472	20 dBm
	5150-5250	23 dBm
	5250-5350	23 dBm
	5470-5725	30 dBm
	5725-5850	14 dBm



Lower power radio LAN product operating in 2.4 GHz and 5 GHz bands. Please refer to the ArubaOS User Guide/ Instant User Guide for details on restrictions.

Medical

1. Equipment not suitable for use in the presence of flammable mixtures.
2. Connect to only IEC 60950-1 or IEC 60601-1 certified products and power sources. The end user is responsible for the resulting medical system complies with the requirements of IEC 60601-1.
3. Wipe with a dry cloth, no additional maintenance required.
4. No serviceable parts, the unit must be sent back to the manufacturer for repair.
5. No modifications are allowed without HPE Aruba Networking approval.

Taiwan

第十二條

經型式認證合格之低功率射頻電機，非經許可，公司，商號或使用者均不得擅自變更頻率、加大功率或變更原設計之特性及功能。

第十四條

低功率射頻電機之使用不得影響飛航安全及干擾合法通信；經發現有干擾現象時，應立即停用，並改善至無干擾時方得繼續使用。前項合法通信，指依電信法規定作業之無線電通信。低功率射頻電機須忍受合法通信或工業、科學及醫療用電波輻射性電機設備之干擾。

1. 應避免影響附近雷達系統之操作。
2. 高增益指向性天線只得應用於固定式點對點系統
3. 電波功率密度 MPE 標準值：1 mW/cm²，送測產品實測值：0.9638 mW/cm²，建議使用時設備天線至少距離人體 25cm

Brazil

Este equipamento não tem direito à proteção contra interferência prejudicial e não pode causar interferência em sistemas devidamente autorizados.

Japan

ご使用になっている装置に VCCI マークが付いていましたら、次の説明文をお読み下さい。

この装置は、クラス B 情報技術装置です。この装置は、家庭環境で使用することを目的としていますが、この装置がラジオやテレビジョン受信機に近接して使用されると、受信障害を引き起こすことがあります。取扱説明書に従って正しい取り扱いをして下さい。

VCCI-B

México

La operación de este equipo está sujeta a las siguientes dos condiciones: (1) es posible que este equipo o dispositivo no cause interferencia perjudicial y (2) este equipo o dispositivo debe aceptar cualquier interferencia, incluyendo la que pueda causar su operación no deseada.

Este equipo ha sido diseñado para operar con las antenas que enseguida se enlistan: https://www.arubanetworks.com/assets/og/OG_AP-580Series.pdf y para una ganancia máxima de antena de 14 dBi.

El uso con este equipo de antenas no incluidas en esta lista o que tengan una ganancia mayor que 14 dBi quedan prohibidas. La impedancia requerida de la antena es de 50 ohms.

Нормативные требования Евразийского Экономического Союза



HPE Russia: ООО "Хьюлетт Паккард Энтерпрайз" Российская Федерация, 125171, г. Москва, Ленинградское шоссе, 16А, стр.3, Телефон: +7 499 403 4248 Факс: +7 499 403 4677

'HPE Kazakhstan': ТОО «Хьюлетт-Паккард (К)», Республика Казахстан, 050040, г. Алматы, Бостандыкский район, проспект Аль-Фараби, 77/7, Телефон/факс: + 7 727 355 35 50

Kazakhstan

ЖШС "Хьюлетт Паккард Энтерпрайз" Ресей Федерациясы, 125171, Мәскеу, Ленинград тас жолы, 16А блок 3, Телефон: +7 499 403 4248 Факс: +7 499 403 4677

ЖШС «Хьюлетт-Паккард (К)», Қазақстан Республикасы, 050040, Алматы к., Бостандық ауданы, Әл-Фараби даңғылы, 77/7, Телефон/факс: +7 (727) 355 35 50

Ukraine

Hereby, Hewlett Packard Enterprise declares that the radio equipment type [The Regulatory Model Number [RMN] for this device can be found in the [Regulatory Model Number](#) section of this document] is in compliance with Ukrainian Technical Regulation on Radio Equipment, approved by resolution of the CABINET OF MINISTERS OF UKRAINE dated May 24, 2017, No. 355. The full text of the UA declaration of conformity is available at the following internet address: <https://certificates.ext.hpe.com>

ХЬЮЛЕТТ ПАКАРД ЕНТЕРПРАЙЗ, 6280 АМЕРИКА ЦЕНТР Д-Р, САН-ХОСЕ, КАЛИФОРНИЯ 95002, США

Philippines

AP-584



Type-Approval No.
ESD-RCE-2230381

AP-585



Type-Approval No.
ESD-RCE-2230391

AP-587



Type-Approval No.
ESD-RCE-2230392

Singapore

Complies with
IDA Standards
DB100427

Contact HPE Aruba Networking

Main Site	https://www.arubanetworks.com
HPE Networking Support Site	https://networkingsupport.hpe.com/home
Airheads Social Forums and Knowledge Base	https://community.arubanetworks.com/
North America Telephone	1-800-943-4526 1-408-754-1200
International Telephone	https://www.arubanetworks.com/support-services/contact-support/
Software Licensing Site	https://www.hpe.com/networking/support
End-of-Life Information	https://www.arubanetworks.com/support-services/end-of-life/
Security Incident Response Team (SIRT)	https://www.arubanetworks.com/support-service/security-bulletins/ Email: aruba-sirt@hpe.com

Warranty

This hardware product is protected by an HPE Aruba Networking warranty. For more details, visit www.hpe.com/us/en/support.html