

Quick Installation Guide

Network Camera Junction Box

*Images may differ from actual products.

©2024 TP-Link 7106510970 REV1.0.0

1 Appearance

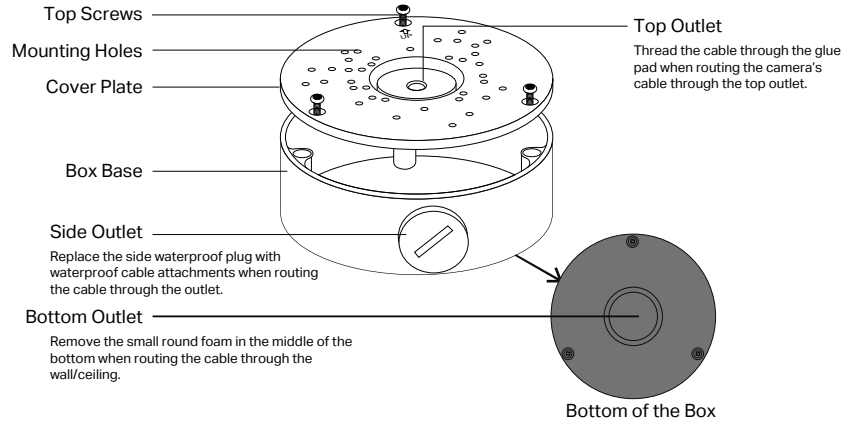
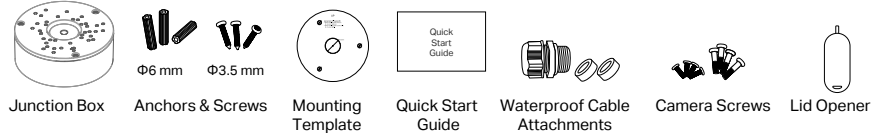

2 Mount the Box

1. Drill Holes

Stick the mounting template to the desired mounting place. Drill 3 screw holes and 1 cable hole (for the cable through wall/ceiling) according to the template.

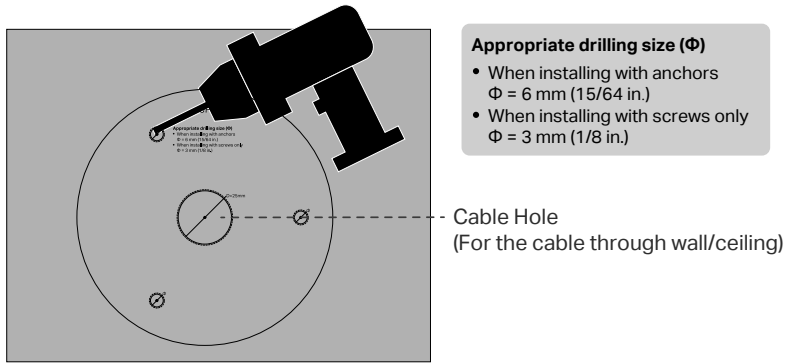

2. Open the Box Case

Use the screwdriver to loosen the screws.

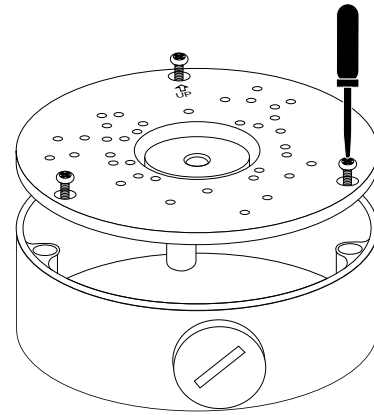

3. Mount the Box Base

Option 1: Route the cable through the wall/ceiling.

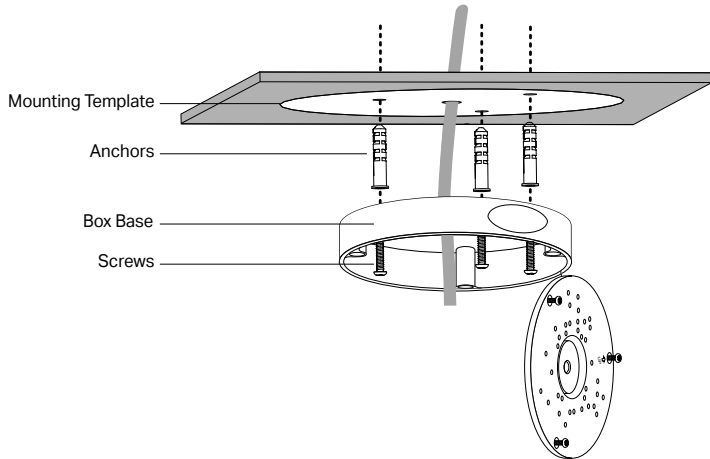

Option 2: Route the cable through the side outlet.

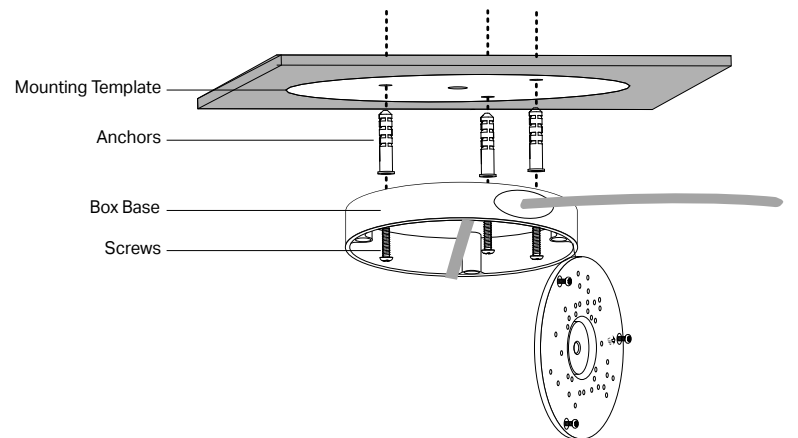

How to Waterproof Cables

When you route the cable through the wall/ceiling, you can refer to your camera's guide to waterproof the cable using the waterproof cable accessories that come with your camera.

For Ethernet cable:

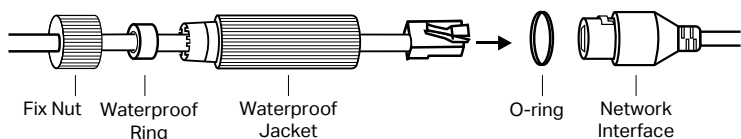

For power cord:

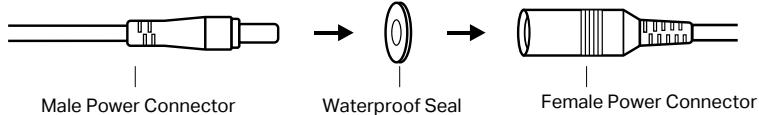

Note: During this process, you can also use some tape to wrap the cable and use the silicone (for outdoor use) or duct seal to weather seal the cable penetrations for better waterproofing.

How to Waterproof Cables

The junction box comes with waterproof cable attachments. You can follow the steps below to waterproof the cables.

1. Use the lid opener to remove the side waterproof plug

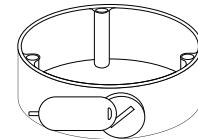

- Route the network cable/power cable through the following components in order: fix nut, waterproof ring, waterproof jacket, and then the side outlet.
- Insert and twist the waterproof jacket securely to the side outlet.
- Rotate the fix nut to secure it to the waterproof jacket.

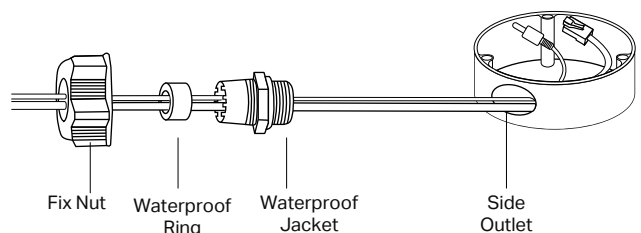

Note: During this process, you can also use some tape to wrap the cable for better waterproofing.

3 Install the Camera

Multiple mounting holes are available for the installation of various camera types to suit different needs.

1. Remove the glue pad, thread the camera's cable through the upper outlet, and reapply the pad.
2. Connect the network cable and power cable as needed.
3. Select the appropriate screws and mounting holes on the junction box according to the table below.
4. Use screws to install the camera to the junction box by referring to the installation guide of your camera.
5. Secure the cover plate to the box base.

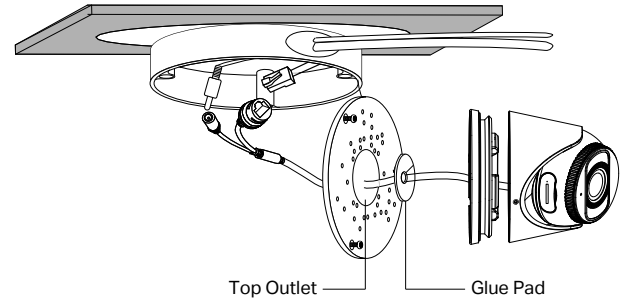

Usage Tips:

1. When installing the camera, some cameras (such as the VIGI C2XX series, VIGI C4XX series, and VIGI C5XX series) may block the top screws. Before installing the camera, secure the cover plate to the box base.
2. It's recommended to install waterproof cable attachments and route the cables into the junction box before installing the camera.
3. If you cannot find your model in this guide, please refer to the latest junction box mounting guide at <https://www.tp-link.com/support/download/vigi-vjb-300/>.

Shape	Models	Screws	Mounting Holes	Shape	Models	Screws	Mounting Holes
	VIGI C320I VIGI C330I VIGI C340I VIGI C330 VIGI C340 *Different versions of these models have different mounting brackets. You can refer to Appendix A to select the appropriate mounting holes.	 Long screws	 Hole 1 and its corresponding holes		VIGI C540V	 Long screws	 Hole 6 and the corresponding holes
	VIGI C350	 Long screws	 Hole 2 and its corresponding holes		VIGI C540 VIGI C540-W VIGI C540S	 Short screws	 Holes 7 and 8 and the corresponding holes
	VIGI C340S VIGI C345 VIGI C355 VIGI C385	 Short screws					
	VIGI C420I VIGI C430I VIGI C440I VIGI C430 VIGI C440 VIGI C440-W VIGI C450	 Short screws	 Hole 4 and its corresponding holes		VIGI C540-4G	 Short screws	 Holes 9 and 10 and the corresponding holes
	VIGI C445 VIGI C455 VIGI C485	 Short screws	 Hole 5 and its corresponding holes		VIGI C220I VIGI C230I VIGI C240I VIGI C230 VIGI C240 VIGI C250 VIGI C230I Mini	 Short screws	 Hole 11 and its corresponding holes

Appendix A: Mounting Holes for Different Brackets

You can choose the appropriate mounting holes according to your camera mounting bracket.

 Hole 1 and its corresponding holes	 Hole 2 and its corresponding holes	 Hole 3 and its corresponding holes

Appendix B: Get the Latest Mounting Guide

If you cannot find your model in this guide, please scan the QR code or visit <https://www.tp-link.com/support/download/vigi-vjb-300/> to download the latest junction box mounting guide.



Scan for Mounting Guide



For technical support and other information, please visit <https://www.tp-link.com/support>.